

TECHNICAL PARAMETERS Vibration exciter S 51010/LS-340

Rated peak force Sine _{pk} /Random _{RMS} ¹ /Shock _{pk} ²	11000/11000/33000 N
Frequency range	2 - 3000 Hz
Main resonance frequency	>2400 Hz
Max. displacement Peak-Peak	50.8 mm
Max. velocity Sine/Random/Shock	2.0/2.0/3.0 m/s
Max. acceleration Sine/Random/Shock	85/70/200 g
Suspension stiffness	75 N/mm
Effective moving mass (±5%)	14 kg
Max. payload	250 kg
Total mass	1100 kg
Magn. stray field Std./low degaussing ³	<1.5/<0.8 mT
Armature diameter	340 mm
Min. required compressed air supply	600 kPa
Interlocks	Field coil temperature, displacement, cooling air, overcurrent, compressed air

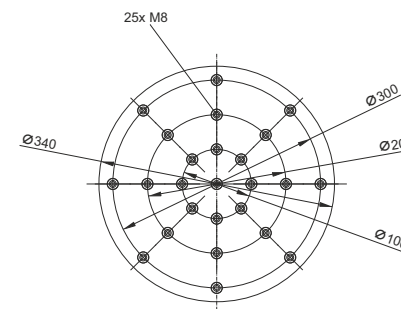
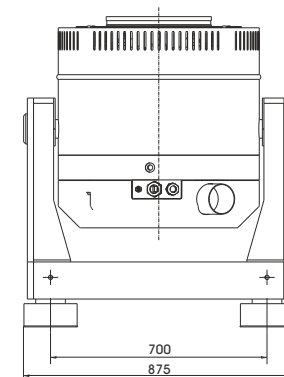
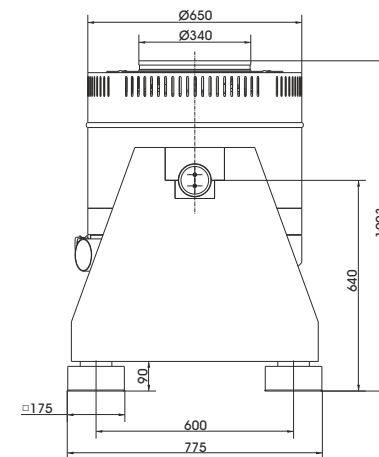

Armature 340 (Standard)

1) Random force according to ISO 5344:2004
 2) Theoretical maximum shock value. Depends on payload, amplifier, shock and shock width
 3) measured at 150 mm above armature
 For long-term tests, the load must be reduced to 80 %. Continuous operation at maximum load can cause damage.

SCOPE OF DELIVERY, OPTIONS AND FEATURES OF THE SYSTEM

<p>Scope of delivery: Vibration exciter 11 kN Trunnion mount Power amplifier 15 kVA Cooling blower Connection cable (5 m) Power cable (5 m) for amplifier (CEE 32 connector) Blower hose Ø140 mm (5 m) Compressed-air hose NW 7,2 (Standard) (3 m)</p>	<p>Options: Different thread inserts in the armature at customer request Low degaussing kit to further reduce stray magnetic field Squeak&Rattle (Silent operation without blower) Wheels&Rails (incl. 3m rails) Thermobarrier (-40°C to +140°C) Chamber leadthrough Climatic chamber support kit Remote control (Software) Silencer for cooling blower (Noise reduction 3 - 6 dB(A)) Acoustic enclosure for cooling blower (Noise reduction 5 - 23 dB(A)) Cable extension Factory acceptance test</p>	<p>Options: TIRA EMS Energy Management System Operation with temperature-controlled cooling blower (and optional with variable field strength) ASM-Mode (Auto Shutdown Manager)</p> <p>Features: Vibration isolation < 6 Hz Coarse filter unit Fully automatic pneumatic load compensation Automatic centering of the armature Degauss kit to reduce stray magnetic field Made in Germany Servicehotline</p>
---	---	---

TECHNICAL PARAMETERS Amplifier A 1 02 11 021 SV

Max. output power _{RMS} (factory-set)	15000 VA
Frequency range	DC - 5 kHz
Voltage _{RMS} , max.	212 V
Current _{RMS} , max. (factory-set)	40-100 A
Signal input voltage _{PK}	±10 V
Total Harmonic Distortion (at 70A _{RMS} , 200 Hz)	< 0.2 %
Signal to noise ratio	> 80 dB
Field voltage (factory-set)	140-280 V
Field current (factory-set)	6-8 A
Total mass	330 kg
Dimensions (WxHxD)	600 x 1740 x 800 mm
Power supply (Standard)	3~ / N / PE 400 V±5% 50 Hz, CEE 32
Recommended fuse protection	32 A slow
Max. power consumption at 400 V (incl. blower)	17 kVA
Interlocks:	Overload, Temperature, Displacement, Cooling air, Compressed air, Phase monitoring, Emergency stop
Features:	
Field supply integrated	
Field voltage/Field current variable according to customer spec.	
4 Sigma peak current	
Mains switch and integrated line filter	
Color Touch Screen	

TECHNICAL PARAMETERS Cooling blower TB 120 FUK

Max. volume flow rate	1500 m³/h
Total pressure difference	10.2 kPa
Motor output	5.5 kW
Max. frequency	100 Hz
Hose diameter	140 mm
Hose length (Std.)	5 m
Total mass	61 kg
Dimensions (WxHxD)	487 x 637 x 487 mm
Max. sound pressure level	102 dB(A)
Power supply (standard)	by amplifier rack
Max. current consumption at 400 V	12 A
Options:	
Silencer TB 120-SI (Noise reduction 3 - 6 dB(A))	
Dimensions (LxD): 1100 x 160 mm	
Mass: 1.2 kg	
Acoustic enclosure TB 120-AE (Noise reduction 5 - 23 dB(A))	
Dimensions (WxHxD): 1250 x 1393 x 1470 mm	
Mass: 103 kg	
Hose length according to customers request (up to 10 m)	

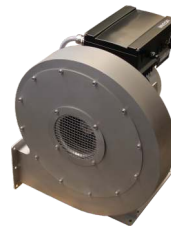

Cooling blower TB 120 FUK



Silencer TB 120-SI (optional)



Acoustic enclosure TB 120-AE (optional)