

## TECHNICAL PARAMETERS Modal exciter S 51140-M

Rated peak force Sine <sub>pk</sub> /Random <sub>RMS</sub> <sup>1</sup>	400/311 N
Frequency range	DC - 5000 Hz
Main resonance frequency (free-swinging)	> 2450 Hz
Max. displacement Peak-Peak	20 mm
Max. velocity	1.5 m/s
Suspension stiffness	5 N/mm
Effective moving mass	0.4 kg
Total mass	18 kg
Coupling thread	M6

<sup>1</sup>) Random force according to ISO 5344:2004

For long-term tests, the load must be reduced to 80 %. Continuous operation at maximum load can cause damage.

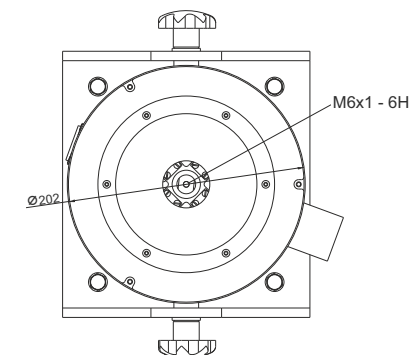
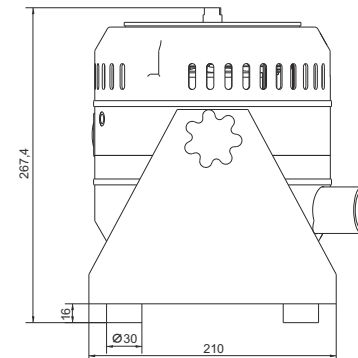
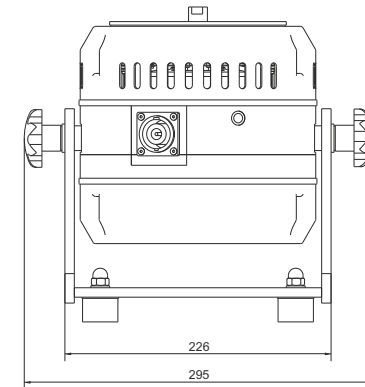

## SCOPE OF DELIVERY, OPTIONS AND FEATURES OF THE SYSTEM

<p><b>Scope of delivery:</b>          Modal exciter 400 N          Trunnion mount          Power amplifier 1200 VA          Cooling blower          Connection cable (5 m)          Power cable amplifier (1.5 m)          Blower hose ø40 mm (3 m)</p>	<p><b>Options:</b>          Rack for mounting the amplifier          Silencer              for cooling blower (Noise reduction up to 8 dB(A))          Acoustic enclosure              for cooling blower (Noise reduction 15 - 23 dB(A))          Stinger (see Modal brochure for details)          Cable extension          Factory acceptance test</p>	<p><b>Features:</b>          Vibration isolation          Coarse filter unit          High cross-axial stiffness          Light weight construction by using rare earth magnet          Minimum maintenance effort          Made in Germany          Servicehotline</p>
---	---	---

## TECHNICAL PARAMETERS Amplifier BAA 1000

Output power <sub>RMS</sub>	1200 VA
Frequency range	DC - 20 kHz
Voltage-/Current mode	yes/yes
Voltage <sub>RMS</sub> max.	72 V
Current <sub>RMS</sub> max.	18 A
Signal input voltage <sub>RMS</sub>	< 5 V
Distortion	< 0.1 %
Signal to noise ratio	> 90 dB
Total mass	35 kg
Dimensions (WxHxD)	483 x 146 x 585 mm
Power supply (Standard)	1 ~ / N / PE 230 V±5% 50 Hz, CEE 7/7
Recommended fuse protection (Standard)	16 A slow
Max. power consumption at 230 V	2.7 kVA
Interlocks:	Overload, temperature, clipping

**Features:**  
High Signal to noise ratio of >90 dB

## TECHNICAL PARAMETERS Cooling blower TB 0140

Volume flow rate	max. 140 m <sup>3</sup> /h
Total pressure difference	max. 150 mbar
Power	1.1 kW
Frequency	50 Hz
Hose diameter	40 mm
Hose length (Std.)	3 m
Total mass	16 kg
Dimensions (WxHxD)	286 x 302 x 292 mm
Sound pressure level, max.	max. 63 dB(A)
Power supply (Standard)	1 ~ / N / PE 230 V±5% 50 Hz, CEE 7/7
Max. current consumption at 400 V	7.3 A

**Options:**  
 Silencer (Noise reduction up to 8 dB(A))  
 Dimensions (LxD): 308 x 82 mm  
 Mass: 0.2 kg  
 Acoustic enclosure (Noise reduction 15 - 23 dB(A))  
 Dimensions (WxHxD): 860 x 760 x 650 mm  
 Mass: 45 kg  
 Hose length according to customers request (up to 10 m)

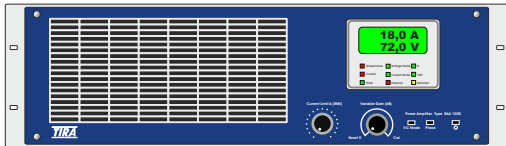

Cooling blower TB 0140



Silencer TB 0140-SI (optional)



Acoustic enclosure TB 0140-AE (optional)